

**Model 23-2HR**

Barrier free, wheelchair accessible Terrazzo Shower Receptor. Reduced threshold height for wheelchair accessibility.

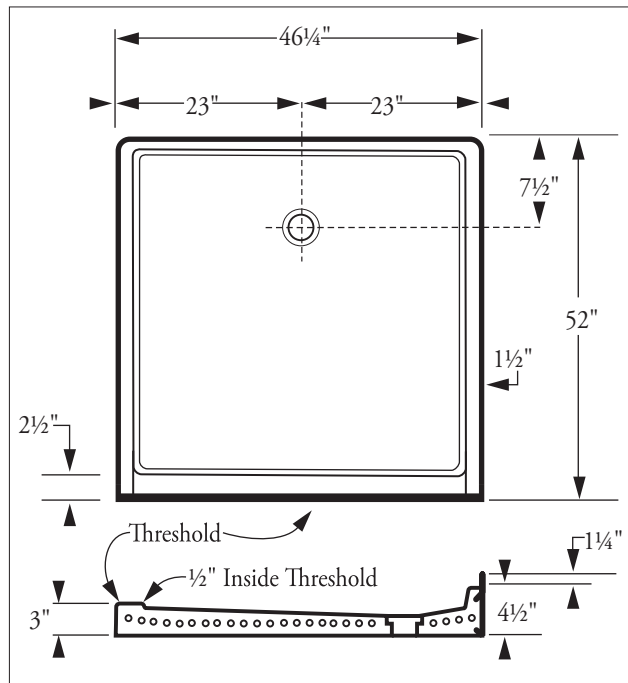

**Florestone  
Model 23-2HR  
Barrier-Free Terrazzo  
Shower Receptor**

46" x 52" x 3"

Weight: 500 lbs.

**Architect's  
Specifications**

Furnish and install wheelchair accessible terrazzo shower receptor Model 23-2HR as manufactured by Florestone Products Company. Flanges on three sides, cast integral, shall be of galvanized-bonderized steel and shall extend not less than 1" above the shoulders. Shoulders on three sides shall be not less than 2 1/2" inside. Threshold shall be not more than 1/2" above receptor floor to allow for barrier free entrance. Drain body shall be brass, cast integral, and shall provide for a non-caulked connection not less than one inch deep to a 2" pipe. Removable type stainless steel strainer plate shall be supplied. Receptor shall be manufactured of tan and white marble chips cast in white Portland cement to produce a compressive strength of not less than 3,000 PSI, seven days after casting. Terrazzo surface shall be ground, polished, and the entire unit sealed to resist stains and moisture after any air holes and/or pits are grouted. Receptors reinforced with 16-gauge wire.



Standards: I.A.P.M.O. File No. 0357



**FLORESTONE PRODUCTS CO., INC.**

2851 Falcon Drive • Madera, CA 93637

T. 559.661.4171 • T. 800.446.8827

F. 559.661.2070 • florestone.com

**Dimensions may vary ± 1/4" inch.  
Please check unit before installation.**

**Place receptor on a minimum 1/4" bed of mortar  
or plaster for warranty compliance.**

**Dimensions subject to change without notice.  
Contact Florestone Products to verify product specifications.**