



FLORESTONE
MODEL 20FM
UTILITY SINK

20" x 24" x 34⁷/₈"

Weight:

20FM-1 (1/Box): 30 lbs.

20FM-3 (3/Box): 85 lbs.

Architect's Specifications

Furnish and install Utility Sink Model 20FM as manufactured by Florestone Products Co. Unit to have four legs and come with hardware to attach legs to the sink. Color will be white and will be resistant to fading and abrasion. Unit to have 1¹/₂" drain opening.

Options and Accessories

20FM Accessory Kit

Drain Plugs with Hardware

Set of Legs (4) – Heavy duty molded legs

Standards



I.A.P.M.O. File No. 2647

ANSI-Z 124.6 -97



CSA Test • Warnock Hersey Listed:

CAN/CSA-B45.0 — CAN/CSA-B45.5



FLORESTONE

Quality Shower and Bath Products Since 1947.

FLORESTONE PRODUCTS CO., INC.

2851 Falcon Dr. • Madera, CA 93637-9287

Tel: 559-661-4171 • Fax: 559-661-2070

www.florestone.com

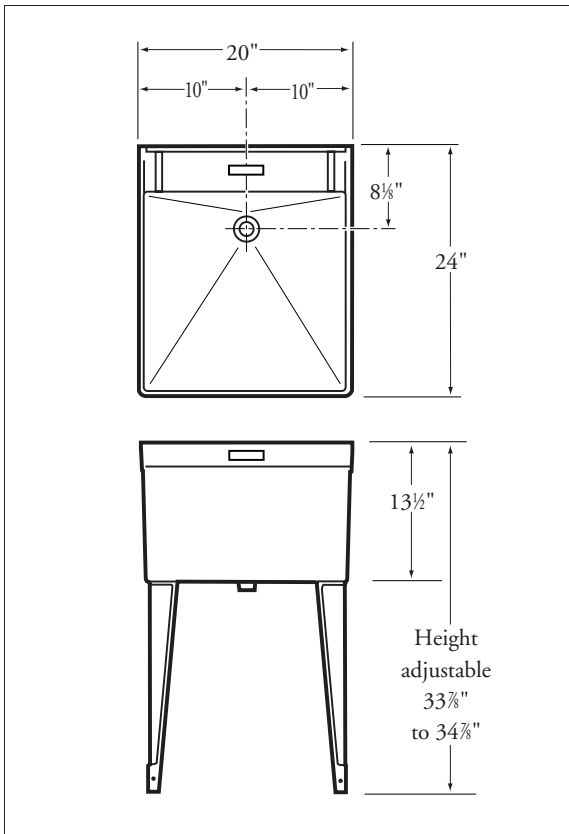

Inside Tray Dimensions: 20" x 19¹/₄"